

High-Load Ball Screws

German-Engineered Precision Components Providing
Maximum Load Capacity and Longer Life in a Compact Envelope



Thomson High-Load Ball Screws – Making the Difference for Motion Control Solutions with Higher Load Capacity

Thomson high-load ball screws move more than twice the load of a standard ball screw, while providing significantly longer and more reliable life with high stiffness and minimum maintenance.

Any new application requires careful analysis of product performance, life and cost. Especially those that take on larger loads. Given that Thomson high-load ball screw technology exceeds more than twice the load capacity of a standard ball screw, it is wise to consider these screws for your next high-load application.

Reliable Performance

Thomson has manufactured ball screws and nuts for more than 50 years in Europe. Our background in flight-critical aerospace and defense applications uniquely positions us to provide the highest levels of quality across all of our ball screw products.

Features & Highlights

- **Increased capacity for high-load applications at high speeds and long lifetimes.**
- **More economic solution vs. roller screws.**
- **Lead accuracy of up to 12 µm/300 mm.**
- **Compact, simple design allows for downsizing, less weight.**
- **Optimized ball nut design for maximizing load capacity.**
- **Available with up to 15 m screw length and with single or double nuts.**
- **Multiple preloading options available.**
- **Smooth, quiet motion.**

Standard and Custom Offerings

Thomson provides a standard range of high-load ball screws from 40 - 160 mm diameter with a maximum of 1,440 kN dynamic load capacity.

The materials used to manufacture ball screws are critical to their performance. Thomson has decades of experience working with a wide range of standard and non-standard materials. Our experts can recommend the materials or coatings best suited for your application.

Customized ball screw assemblies according to specific application demands are also available upon request.

Consistent Quality and Delivery

A combination of advanced engineering and proprietary manufacturing processes consistently exceed performance, precision and life versus comparable ball screws.



Made for the Most Demanding Industrial Applications

Regardless of the technical challenge, Thomson can help you find the solution to best match the optimal requirements for load, speed, stiffness, accuracy and life.

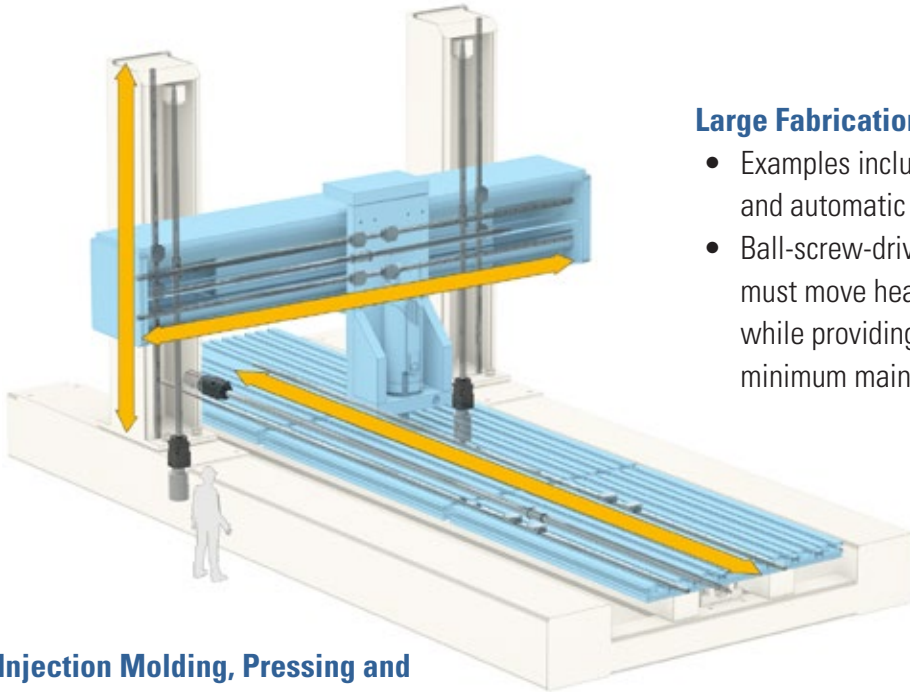

Large Fabrication Machines

- Examples include mills, water jets, plasma cutters and automatic welders.
- Ball-screw-driven horizontal and vertical axes must move heavy loads accurately and safely, while providing long and reliable life with minimum maintenance.

Injection Molding, Pressing and Metal Fabrication Machines

- Ball screws are necessary to handle high-loads in a short stroke.
- Precision ball screws are required to control system accuracy and product tolerances.

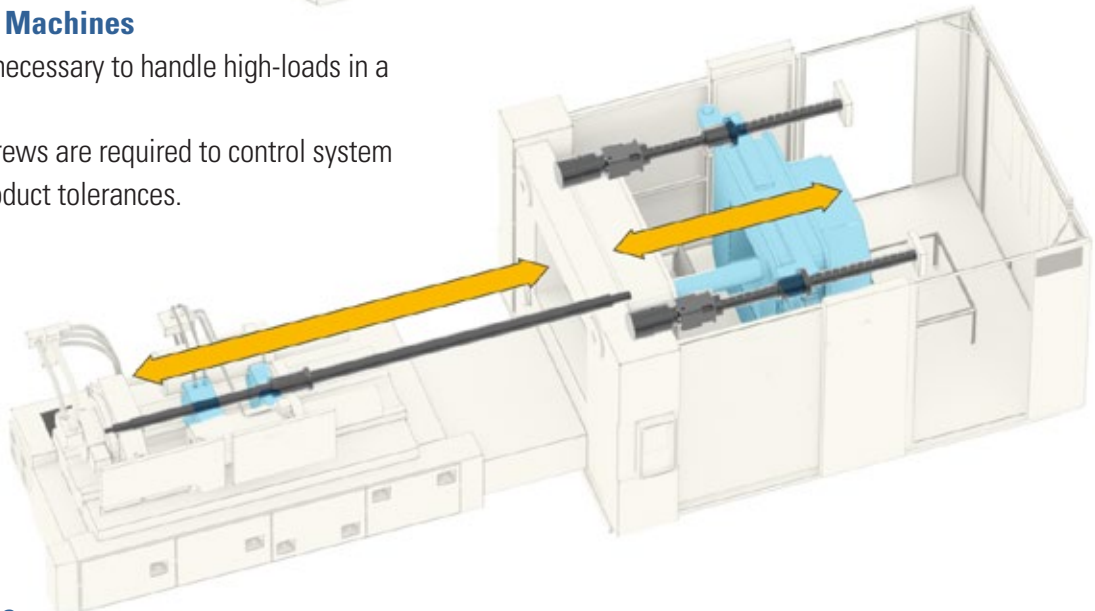

More Applications

- Metal pressing and forming (e.g. rivet presses, servo presses, tube bending, metal sheet bending, test rigs, straightening machines)
- Machine tools
- Lifting devices
- Large valves
- High-load actuators, electromechanical conversion

How Do Thomson High-load Ball Screws Compare to Other Screw Technologies?

Screw Technology Comparison			
	Standard Ball Screw	High-load Ball Screw	Roller Screw
Size Compactness	★ ★	★ ★ ★ ★	★ ★ ★
Price	★ ★ ★ ★	★ ★ ★	★

Higher Load Capacity, Longer Lifetime

The life of the assembly is a direct function of the load capacity. Thomson has developed a high-load ball screw by implementing a unique design that provides longer lifetimes when compared to traditional ball screws. Using a high-load ball screw in a low-load application extends the life of the product four to eight times.

A longer lifetime makes Thomson high-load ball screws an attractive option for engineers looking to replace a roller screw or hydraulic system in their applications.

Cost Savings, Smaller Footprint

High-load ball screws offer a space-saving design at an economical price.

A standard configuration ball screw is capable of providing a high-load solution but would require a larger screw diameter, which adds to cost and footprint needed.

A roller screw is also capable of moving high-loads, but has a nut that is close to 50% larger at 150% the price of a comparable high-load ball screw.

Roller screws also require extensive upfront precision machining and a more complex assembly, which contributes to an overall higher cost and larger footprint for final installation.

Thomson high-load ball screws improve performance in a smaller package, extend product life and save money. Their unique design increases the ball screw load capacity, resulting in an ideal fit for any application with a need for high thrust.

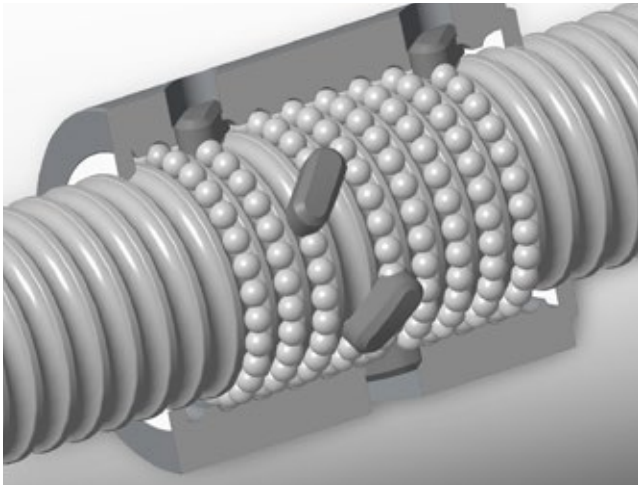

Thomson high-load ball nuts offer a faultless, gentle recirculation of the balls and precise positioning.

Standard Options

Standard sizes up to 160 mm in diameter with a maximum dynamic load of up to 1,440 kN are available. Thomson also customizes to your specific application needs. Contact Customer Service at thomson.europe@regalrexnord.com with your request.

Standard Range of High-load Ball Screw Sizes

Diameter (d_0) [mm]	Lead (P_h) [mm]	D_w [mm]	D_1 [mm]	i [each]	L [mm]	C_{am} [kN]	C_{0am} [kN]	D_4 [mm]	D_5 [mm]	D_6 [mm]	D_B [mm]	L_1 [mm]	L_3 [mm]	L_7 [mm]	L_8 [mm]	L_{10} [mm]
40	12	7.938	75	8	165.0	220	434	93	11	110	M8x1	25	7	16	85	10
50	20	9.525	90	5.8	152.0	259.4	603.4	108	11	125	M8x1	25	7	20	95	10
50	25	9.525	90	5.8	177.5	258	600.9	108	11	125	M8x1	25	7	20	95	10
50	100	9.525	90	2.4	111	100.8	231.8	108	11	125	M8x1	25	7	16	95	10
63	20	12.700	105	8	249.0	478.6	1108.7	125	13.5	145	M8x1	25	9	25	110	10
63	25	12.700	120	5.8	185.5	419.8	1002.2	145	13.5	165	M8x1	30	9	25	130	10
80	20	14.288	135	9	280.5	690.2	1860.8	155	13.5	175	M8x1	30	9	30	140	10
80	25	14.288	135	7	273.0	554.8	1445	155	13.5	175	M8x1	30	9	30	140	10
100	20	14.288	160	8	252.0	709.3	2276.5	186	17.5	212	M8x1	40	10	30	165	10
100	25	19.050	160	8	310.0	968.4	1843.8	189	17.5	212	M8x1	40	10	30	165	10
125	20	14.288	200	11	338.0	1040.1	3997.8	233	22	265	M8x1	40	10	40	205	10
125	25	19.050	200	9	349.0	1238	2753.2	233	22	265	M8x1	40	10	40	205	10
125	30	19.050	200	7	330.5	996.3	2139.6	233	22	265	M8x1	40	10	40	205	10
160	20	14.288	260	12	357.0	1279.9	5870.3	300	22	340	M8x1	40	10	45	265	10
160	25	19.050	260	9	354.0	1440.8	3772.8	300	22	340	M8x1	40	10	45	265	10
160	30	19.050	260	8	370.5	1301.2	3351.9	300	22	340	M8x1	40	10	45	265	10

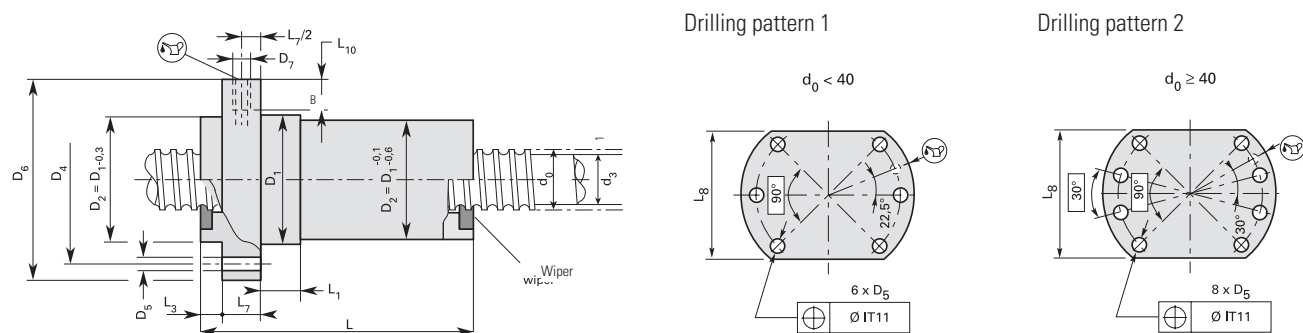

Ordering Key Example

1	2	3	4	5	6	7	8	9	10	11	12	13	14	15	16	17													
KGT	-	H	-	100	20	-	P5	-	RH	-	K	105	-	1003	-	K	025	-	F	-	E	-	EE	-	G	-	0	-	0

This ordering key is an example. Contact Thomson Customer Service teams for specific ball screw configurations: sales.europe@thomsonlinear.com.

Contact us or any of our 2000+ global distribution partners by scanning the code below
or visiting www.thomsonlinear.com/contact



RegalRexnord™

www.regalrexnord.com

www.thomsonlinear.com

High_Load_Ball_Screws_BREN-0029-05 | 20260120SK | MCB-12387-TL-EN-US 02/26
Specifications are subject to change without notice. It is the responsibility of the product user to determine the suitability of this product for a specific application. All trademarks property of their respective owners. ©2026 Thomson Industries, Inc. | 2400 Curtiss Street, Downers Grove, IL 60515 USA

THOMSON®